



**DEPARTMENT OF CIVIL ENGINEERING**  
AALBORG UNIVERSITY

# Review of 5kW wave energy LOPF buoy design study and test

ForskVE 12056

# Review of 5kW wave energy LOPF buoy design study and test

**DCE Technical Report No. 233**

by

Lucia Margheritini

November 2017

© Aalborg University

## Contents

Preface .....	4
Development stages .....	5
Future: Scale 1:1 .....	7
Compliance with the target power curve in the no.12056 project. ....	10
Conclusions .....	12

## Preface

This report has been prepared by Aalborg University for the ForskVE project 12056: **5 kW wave energy LOPF buoy design study and test.**

AAU has the role of reviewing and advising on the data analysis, besides compiling this report.

The purpose of this project was to document the mechanical power production against a target power curve of a 5kW grid connected wave energy buoy in Nissum Bredning at Helligsø. This test site is typically used for open sea testing of scale 1:10 devices in irregular waves. In order to better adapt to the moderate wave height, the buoy was down sized by a factor of 3 and a new lower target power curve for the buoy was agreed to. Downsizing the project also had the advantage that it is more cost effective and fast to experiment with small wave energy devices than with big devices, at an early development stage, in line with the TRL and four phases development (proof of concept, design and feasibility study, field trials and half or full-scale trials) promoted by AAU and supported by the marine renewable energy sector. To complement this, the IEC 114 standards define 3 stages of testing (1=small scale and no scaled version of PTO, 2=PTO represents a realistic full-scale PTO with adjustable control strategies, 3=realistic PTO function and full-scale machine with all electrical component working as they should).

With this project LOPF classifies somewhere in stage 1-2 of the IEC 114 and stage 2-3 of the AAU four stages of development.

## Development stages



**Year 2011/12 stage 1** of the IEC 114 standards for testing wave energy devices: design validation and testing in regular waves. Design optimization in Irregular waves, scale 1:25.

**Innovation:** redesign of the external float and mooring.

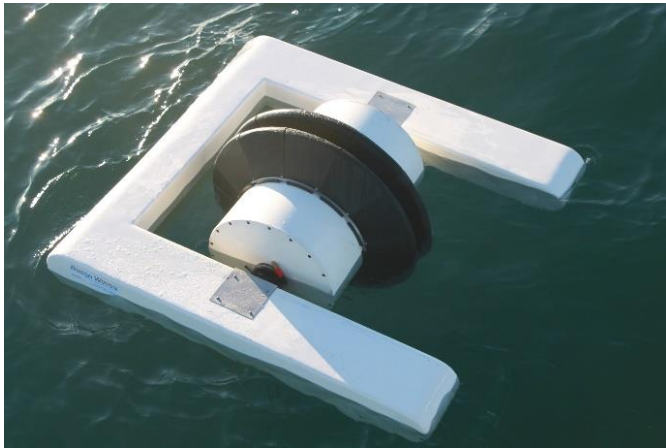

**Year 2017 stage 2** of the IEC 114 standards for testing wave energy devices: performance verification in Nissum Bredning test site, DK (scale 1:10 of the North Sea). All components were tested in realistic sea waves, including full PTO, mooring and the remote integrated monitoring system.

**Innovation:** materials of the main float and PTO components.

The buoy tested has overall dimensions of 170 x 170 x 100 cm, dry weight between

250 and 350 Kg and a generator of 300W.

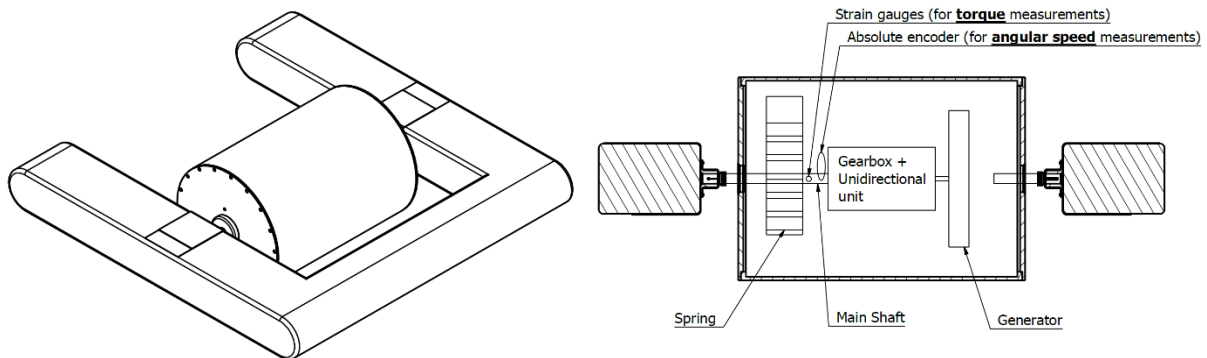

The minimum and maximum mechanical power measured are 20 and 70 W respectively across wave height from 0.15 to 0.60 m. The Max. efficiencies (>70%) were achieved for wave heights between 0.15 and 0.25 m and periods between 1.6 and 2.2 s, which were also the most probable waves at location recorded during the testing period (Figure 1-3).

For its compactness and simplicity of installation, this small version of the Resen Waves buoy will be the first product of the House. The application of these machines includes isolated communities, summerhouses, remote monitoring operations, etc.

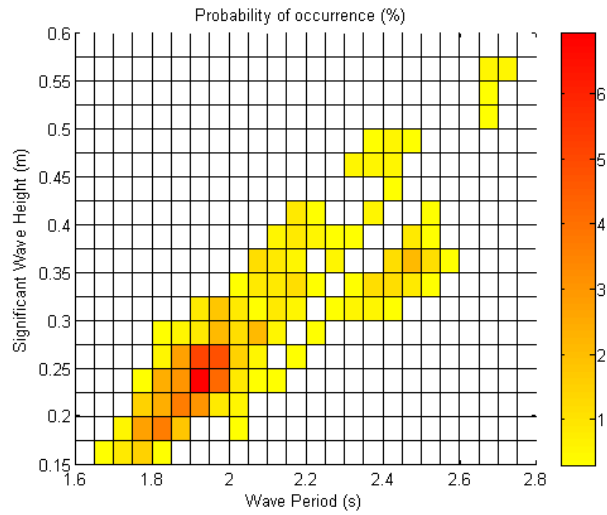

Figure 1. Probability of occurrence of combined wave heights and periods during testing in Nissum Bredning.

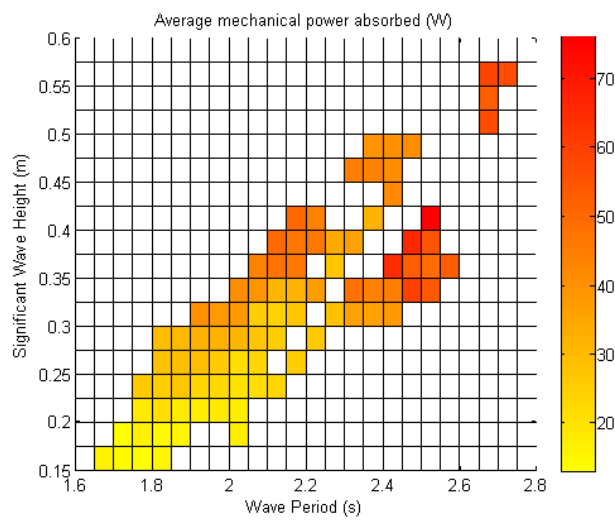

Figure 2. Measured Average Mechanical power absorbed for different wave conditions in Nissum Bredning.

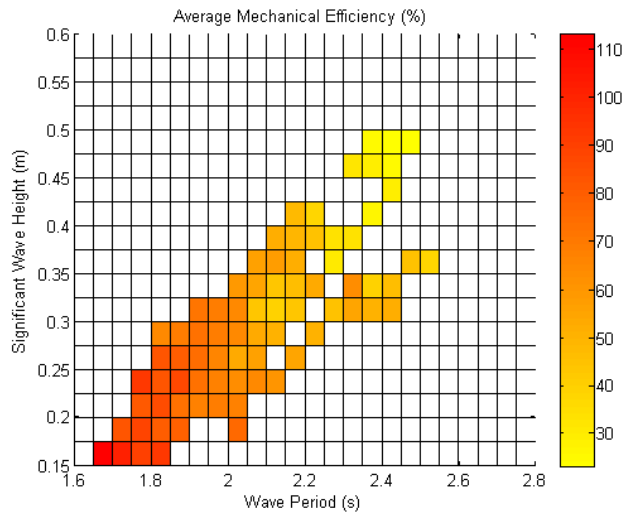

Figure 3. Calculated average mechanical efficiency for wave conditions encountered in Nissum Bredning.

**Year 2017-2018 stage 3-4** of the IEC 114 standards for testing wave energy devices: the buoy will continue the sea trials in Nissum Bredning, DK with fully operational PTO (generator and inverter) to verify the power output and finalize the optimal control strategy. Because the scale 1:10 will be also regarded as a full scale for less energetic conditions, the stage of development is then 3-4 and includes technical deployment and materials characterization and optimization.

**Innovation:** Gear box, generator and inverter.

#### Future: Scale 1:1

Despite the 300 W device being developed as a full-scale machine for low energetic locations, the concept will also be built in 1:1 scale to North Sea conditions, with a geometry optimized for bigger waves (Fig 4) and adequate generator capacity. This concept will be most likely marketed to utilities and governments, as opposite to the 300 W buoy that can be a product for privates and individuals.

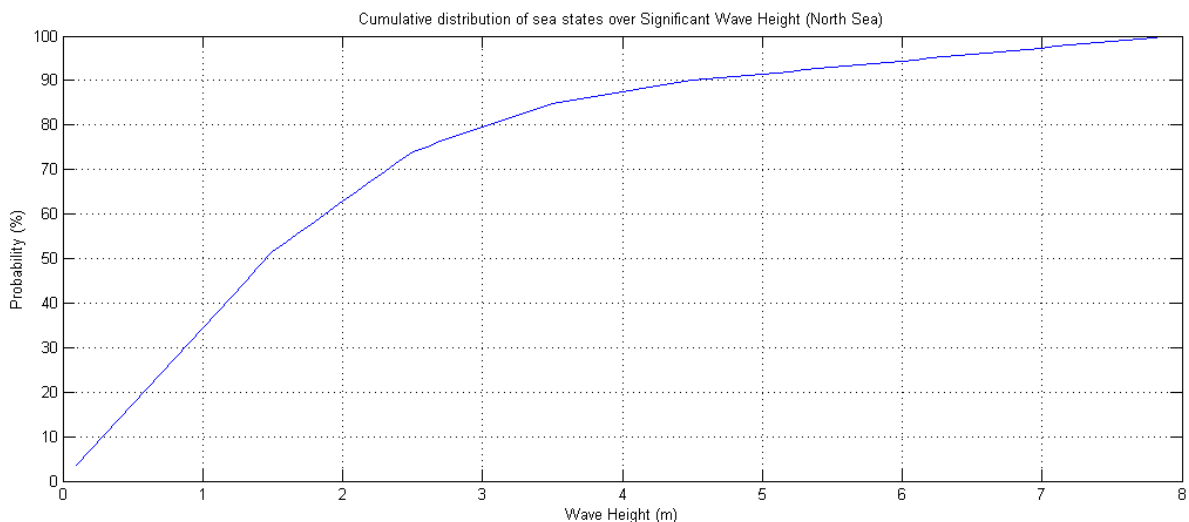

Figure 4: 1:1 wave height distribution.

We can calculate the expected power production of the 1:1 device using the efficiencies obtained in the sea trials in Nissum Bredning. This, based on the hypothesis that Stage 3-4 confirms the results

obtained with regards to the mechanical absorbed power (Fig 5), and that a suitable gear + generator + inverter is used.

We will assume a 1:1 scale factor for the width of the device, which we will consider also to be the capture width. The operational sea states the North Sea are divided in 7 conditions and the available power for each of them, considering the capture width of 14 m is presented in the third column of Table 1. The probability of occurrence for each sea state, is reported column 4 (waves smaller 0.5 m are disregarded and so extreme events). With the mechanical efficiencies available today, the estimated mechanical power for each sea state for the 1:1 device is presented in column 7. We then must assume an efficiency for the generator and inverter as it hasn't been tested yet, but 80% is credible. Therefore, the power production in the North Sea for each sea state is estimated in column 9.

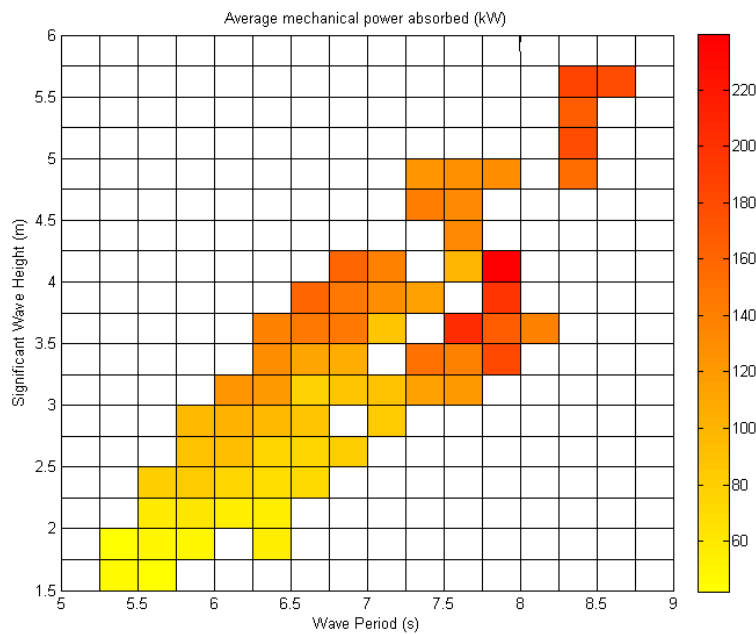

Figure 5. Estimated average mechanical power 1:1

Table 1. Expected 1:1 results.

Hs (m)	T (s)	Wave power (kW/m)	Occurrence of the sea state (-)	Available Wave power *14 m *probability (kW)	Measured mechanical efficiency (-)	Estimated mechanical power (kW)	Estimated power Generator out (kW)	Estimated power production (kW)
1	4,6	2,2	0,468	15	0,9	13	11	11
2	5,7	11,1	0,226	35	0,9	32	25	25
3	6,8	45,2	0,108	45	0,57	26	21	21
4	7,9	44,1	0,051	44	0,25	11	172,88	9
5	9,0	36,9	0,024	37	0,2	7	246,18	6
6	10,2	22,6	0,009	23	0,1	2	200,89	2
7	11,3	15,1	0,004	15	0,5	8	1514,58	6
Sum of sea state contribution to the average available wave power for 14 m capture width (kW)				214	Sea state contribution to average generated power (kW)		79	



So, we would need 1.5 MW installed capacity in order to obtain 79 kW. But most of the most energetic waves do not contribute significantly to the power production. Therefore, more realistically, if we decide not to fully cover the most energetic sea states with lower probability of occurrence, we obtain different load factors (LF= produced kW /installed kW) and power productions:

For an installed capacity is 50 kW, LF = 63%, and average power production is 32 kW and 278 MWh/y of energy.

For an installed capacity is 100 kW, LF = 53%, and the average power production is 53 kW, corresponding to 463 MWh/y.

For an installed capacity is 200 kW, LF = 36%, and the produced power is 73 kW for 638 MWh/y.

For an installed capacity is 300 kW, LF = 25%, and the average power production is 74 kW, corresponding to 651 MWh/y of energy.

It is also expected the power will increase when the revolution range of the spring is increased in future designs. The existing spring in the buoy at the time of testing in Nissum Bredning can only be wound up 250 degrees which allows a vertical displacement of only 1,1m from slag to 100% tightened spring. This would explain the power production efficiency is very high in the smallest waves and drops off in bigger waves.

A new spring which allows up to 790 degrees winding up and can therefore provide an estimated vertical movement of up to 4m displacement is under development and should be available in the future. This would increase the power in bigger waves flattening efficiencies in bigger waves for a better power absorption.

## Compliance with the target power curve in the no.12056 project.

In this chapter obtained logged data will be plotted against the target curve. All data is recorded in random waves. The performance of the buoy against the agreed target power curve is presented in table 2:

Table 2: Target power curve by average wave height  $H_m$

<b><math>H_m</math> [cm]</b>	<b>Mechanical Power [W]</b>
0	0,0
7	0,9
13	4,6
20	12,2
27	21,5
33	30,0
40	39,5
47	50,3
53	60,2
60	72,5
67	85,6
73	97,3
80	111,7
87	126,6
93	140,0

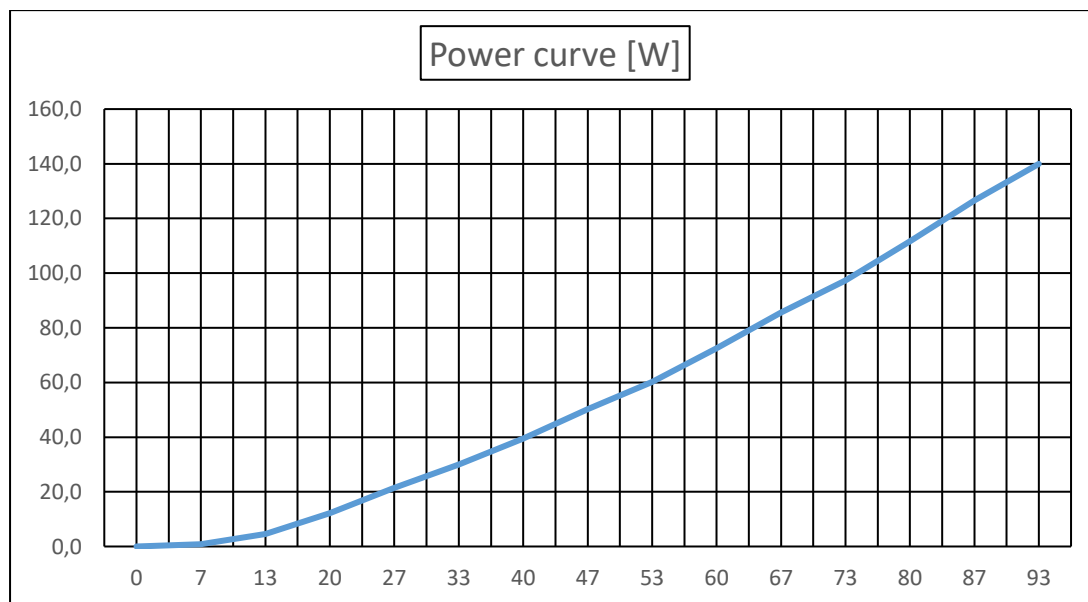

Figure 6: Extrapolation of Power curve from sea trial in Nissum Bredning, Power [W] vs.  $H_m$  in [cm].

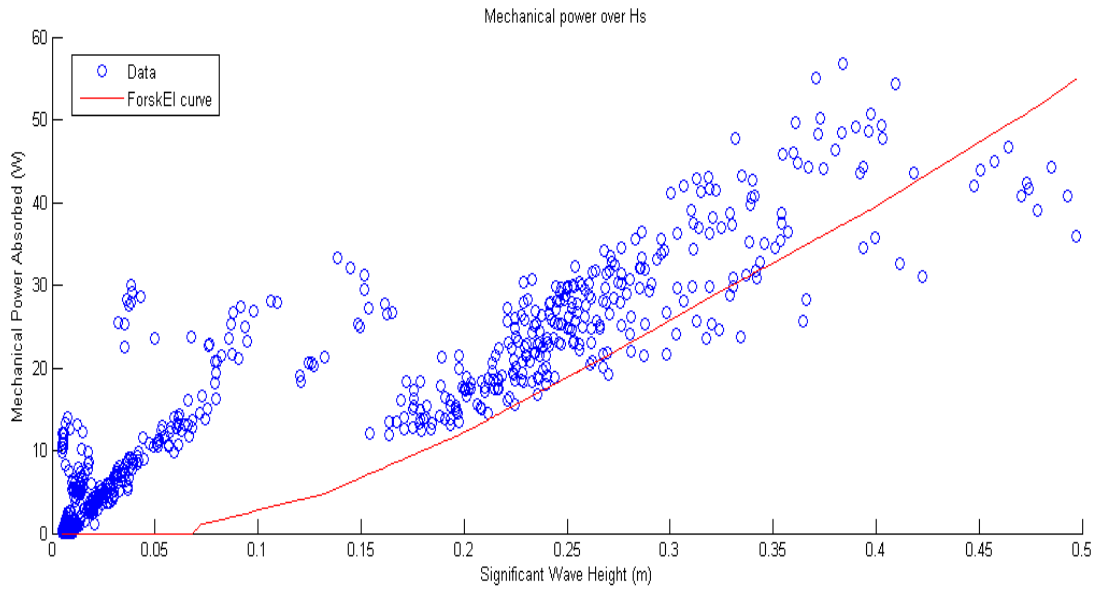

Figure 7: Measured data in Nissum Bredning (blue circle) vs expected curve (red).

The power figures during the measuring campaign are shown against the reference target power curve (Fig 7). For the majority of the data point, the LOPF exceeded the expected performance by 88% on average.

Each blue dot represents the results for the mechanical power absorbed during one sea state (during 15 minutes). In this random example 350 valid results, out of 383, are on or above the red target power curve, which is 88% on or above target, which is typical for all the measurements. Each dot represents a 15-minute average power production and average significant wave height against the red, target power curve.

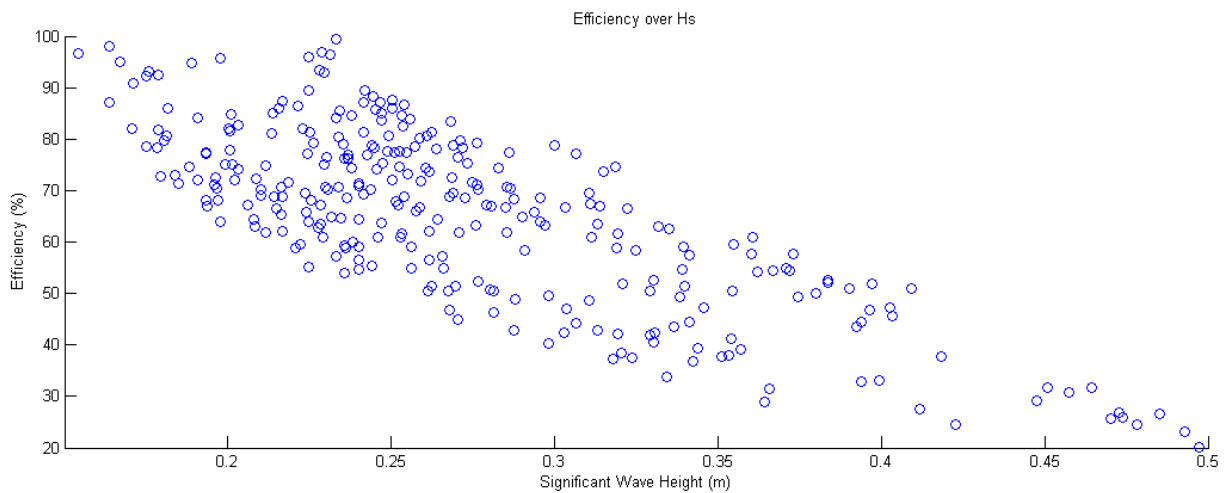

Figure 8: Measured mechanical efficiencies in Nissum Bredning.

Fig. 8 shows typical distribution of efficiency vs  $H_m$ . The efficiency drops off in bigger waves because the spring range is limited to 250 degrees in revolution. By using a spring with a bigger range in revolution the high efficiency will be spread out to bigger waves, as well.

## Conclusions

- Design and construction of the LOPF buoy with data acquisition system and PTO have been achieved successfully. These achievements and the realization of the tests classify the LOPF at stage 2-3 in the AAU phases of development and 1-2 in the IEC 114 standards for the Marine Energy sector.
- The buoy until now operated for 720 hours equivalent to 30 days in the relevant sea environment.
- The mechanical power vs the significant wave height has been monitored and documented against the target power curve for a period of 750 hours of which it has been on or over performing the target curve for 660 hours. The requirement for the ForskVE contract was minimum 600 hours.
- The buoy will continue the operation in the sea for another 3 to 6 months.
- The min. and max. mechanical power measured here are 20 and 70 W respectively across wave height from 0.15 to 0.60 m. Max. efficiencies (>70%) were achieved for wave heights between 0.15 and 0.25 m and periods between 1.6 and 2.2 s, which were also the most probable waves at location recorded during the testing period.
- The full-scale buoy for North Sea conditions has been discussed in detail. The estimated power production for an installed capacity is 100 kW, the load factor LF = 53%, and the average power production is 53 kW, corresponding to 463 MWh/y.

**Recent publications in the DCE Technical Report Series**

**Review of 2 kW grid connected LOPF tests in Nissum Bredning**

**ISSN 1901-726X**

**DCE Technical Report No. 231**