

EUDP 11-I, J. nr. 64011-0076

Heat Pumps for Domestic Hot Water Preparation in Connection with Low Temperature District Heating

October 2013

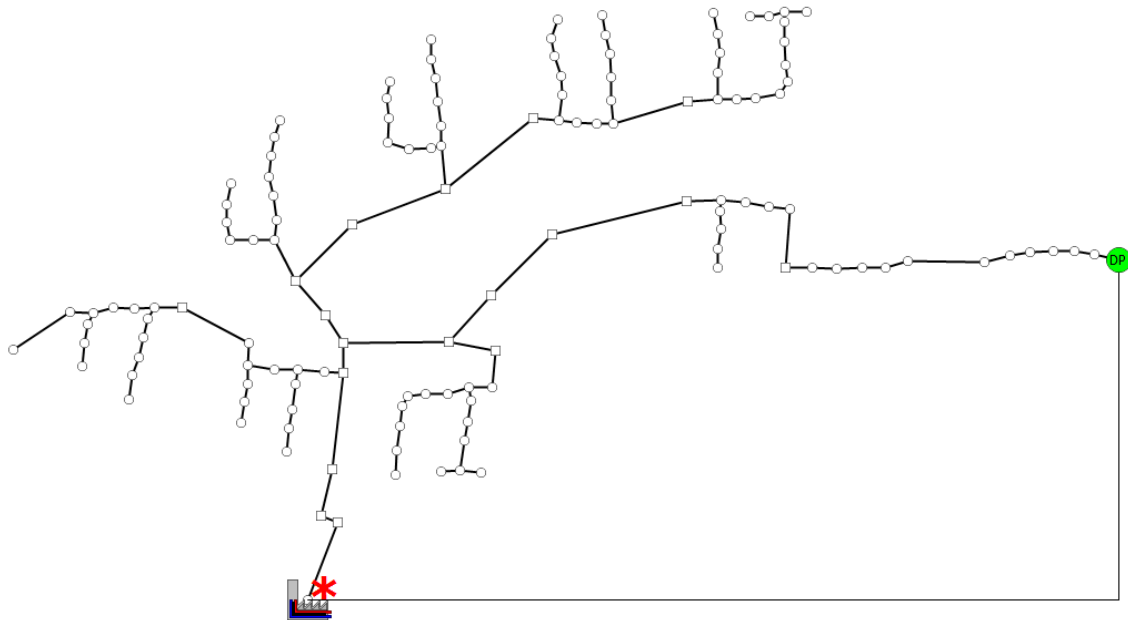

Published : 22 Oct. 2013
Project : 30.9026.01

Prepared : Michael Markussen, Brian Elmegaard, Torben Schidt Ommen, Marek Brand, Jan Eric Thorsen

Checked : Johnny Iversen

TABLE OF CONTENTSPAGE

1	INTRODUCTION.....	5
1.1	Background.....	5
1.2	Objective	5
1.3	Project description.....	6
2	PROJECT SCOPE AND OVERALL SYSTEM ANALYSIS.....	8
2.1	Scope.....	8
2.2	Heat demand analysis.....	9
2.3	Network considerations	11
2.4	Concept and system analyses.....	13
2.4.1	Hot-water tank on the primary side	13
2.4.2	Hot-water tank on the secondary side.....	14
2.5	Comparison with other technologies.....	15
2.6	Further concept analyses and design.....	15
2.7	Potential assessment	15
2.7.1	Introduction.....	15
2.7.2	Assessment of potential in Denmark.....	16
2.7.3	Assessment of potential outside Denmark.....	18
3	DETAILED SYSTEM ANALYSIS.....	19
3.1	Detailed concept description	19
3.2	Dimensioning of hot-water tank.....	20
3.3	Selection of concept for prototype	22
4	DEVELOPMENT OF PROTOTYPE UNIT	23
4.1	Design parameters.....	23
4.2	Detailed description of functionality	24
4.3	Test results	26
5	DEMONSTRATION AND IMPLEMENTATION	29
5.1	Demonstration site	29
5.2	Implementation	30
5.2.1	District heating distribution network	30

5.2.2	Shared heat exchanger	31
5.2.3	Micro Booster unit.....	32
5.2.4	Efficiency of DHW production	34
5.2.5	Domestic hot circulation water	35
5.2.6	Tariff system.....	36
5.3	Test results	36
6	DISSEMINATION.....	39
7	CONCLUSIONS AND NEXT STEPS	40
8	REFERENCES	41

APPENDICES

Appendix 1: Heat Demand Analysis, Work Package 2, DTU Byg

Appendix 2: Traditional Network vs. LTDH Network with Heat Pumps, Work Package 2,
Grontmij

Appendix 3: Basic Concepts of Hot Water Supply in Low Temperature District Heating
Networks, Work Package 2, DTU Mek.

Appendix 4: Calculations on Different Concepts for LTDH HP, Work Package 3, DTU Mek.

Appendix 5: Domestic Hot water and District Heating Water Storage Tanks, Work Package 3,
Danfoss

Appendix 6: User Manual for DH unit (in Danish), Danfoss

ABBREVIATIONS

CHP	Combined Heat and Power
COP	Coefficient of Performance
DH	District Heating
DHR	District Heating Return
DHS	District Heating Supply
DHW	Domestic Hot Water
FH	Floor Heating
HX	Heat Exchanger
PHX	Plate Heat Exchanger
LTDH	Low Temperature District Heating
RE	Renewable Energy

SUMMARY

The scope of the present project is to develop and demonstrate a new low temperature district heating unit with an integrated heat pump (micro-booster) for hot tap water preparation. The district heating supply temperature is in the range of 35-45°C.

Today, approximately 25-30 % of the annual heat demand of family houses in Denmark is used for domestic hot tap water – the rest for space heating. New houses built in accordance with the new building codes require much less heat and the share of heat used for domestic hot tap water is rapidly approaching 50 % of the annual heat demand. Furthermore, more circulation is needed as the heat off-take from the network is diminishing. Reducing heat losses in the network is becoming increasingly important in order for district heating to be competitive with alternative heating solutions. Low supply temperatures present a solution to these challenges.

The capacity of a low temperature network decreases with the temperature difference between supply and return temperature, but on the other hand the specific consumption also decreases under the new building codes as mentioned above.

The heat loss is approx. 40-55% lower in newly designed low temperature district heating networks compared to traditional 80/40°C networks.

In order to keep investment costs down, it is recommended to design new low temperature district heating networks for a temperature difference between supply and return of at least 40°C during peak hours. The supply temperature should therefore be raised during peak hours.

Various system concepts for integration of micro-booster heat pumps have been analysed. The best configuration turned out to be a directly connected system with the hot water tank placed on the primary side. The advantage of this system is its ability to store relatively low temperature water at approx. 50°C without any legionella problems and it has a good exergetic efficiency.

The application potential of the micro-booster concept is huge. It can be applied in newly designed areas (networks and houses), actually increasing the capacity of the existing district heat networks by using the return water as supply source, and especially in connection with renewable energy systems such as solar heat, geothermal heat, excess heat, heat pump systems etc.

The benefit of improved conversion efficiency at CHP plants due to the lowered return temperature turns out to be of less importance if electricity prices are low. The driver for the low temperature concept is system integration with the selected heating source.

The direct connection sets a limit to the allowed pressure in the network and the demonstration showed that integration in houses with existing circulation systems caused some problems. The concept is therefore not recommended in connection with a hot tap water circulation system.

The micro-booster has a COP of approx. 4.5 on the flow through the booster unit. The overall system COP for hot tap water preparation considering the total hot tap water consumption of the house is many times higher due to the heat used for the supply temperature.

The demonstration project implemented in Birkerød north of Copenhagen shows that the system works according to the expectations and intentions. Due to a delay in implementation, the system has only been in operation since spring 2013. Even though the EUDP project has ended, the implemented demonstration system will stay in operation for another year, where after it will be decided whether to keep the system or switch back to normal district heating operation.

The implemented system faced some minor problems in the beginning, for example ventilation needs at specific places and problems with regulating the existing circulation system for domestic hot tap water.

The high COP is verified and in general the system shows good performance and resilience.

Next step in the development of the low temperature district heating unit should be a demonstration project covering some 10-15 more modern houses without an internal circulation system for hot tap water. The unit itself only needs some minor adjustments - no conceptual changes are required.

Further, it should be demonstrated how big a share of the annual heating demand of existing houses can actually be supplied by low temperature district heating without raising the temperature during peak hours on cold winter days.

Finally, a demonstration of the concept in connection with heat supply from renewable sources (e.g. solar, geothermal, major heat pumps) or low temperature waste heat would highlight all the advantages of the system.

1 INTRODUCTION

This report marks the conclusion of the project “Heat Pumps for Domestic Hot Water Preparation in Connection with Low Temperature District Heating” funded by the Energy Technology Development and Demonstration Programme (EUDP). The application for the project was submitted 4th March 2011 and approved 28th June 2011. The project was initiated 1st August 2011 and ended 31st July 2013.

Project partners are:

Grontmij A/S, Project Manager
 Danfoss A/S
 DTU Mekanik (DTU Mechanical Engineering)
 DTU Byg (DTU Civil Engineering)
 Nordforbrænding A/S*

*Gladsaxe Fjernvarme was initially partner in the project, but was replaced by Nordforbrænding A/S because the planned construction of the new houses in Bytoften, where the pilot heat pump units were to be installed and tested, was cancelled. Instead, four houses were selected in the area of Birkerød, which is in the supply area of Nordforbrænding.

1.1 Background

The increased requirements of the Danish building regulations combined with the planned extension of the Danish district heating (DH) network as a key factor in the future effective and fossil free energy system, pushes the development towards low temperature district heating (LTDH) systems applying temperatures as low as 35-45° C. LTDH has considerable advantages compared to traditional DH:

- Lower heat loss from network
- Better opportunities for integration and utilization of renewable energy sources such as solar heating and geothermal energy and also waste heat from the industrial sector
- LTDH can be distributed from the return side which enhances utilization and improves the capacity of existing infrastructure
- Reduced return temperatures on the DH network result in improved efficiency of power plants.

Due to challenges with health aspects related to the use of domestic hot water (DHW), LTDH has mainly been tested on LTDH systems with 55° C supply temperature, where the temperature of the DHW is set to 45° C. Thus, the full potential of LTDH, which is in the temperature range between 35 and 45° C, is not achieved.

1.2 Objective

The overall objective of the EUDP project is to prove the viability and promote the development of LTDH (35°-45° C) as a technology by developing and testing an integrated heat pump unit for production of DHW in individual households.

More specifically, the aim of the project is to develop and test a robust and competitive heat pump unit for producing DHW that leads to improved energy efficiency and economy in the entire DH system. Key design parameters include use of a natural refrigerant, high COP and small size. Further, the unit has to be user friendly, easy to install and service and the energy efficiency compared to other solutions must be documented.

1.3 Project description

The project is divided into two overall phases:

Phase 1: Analysis and development

Phase 2: Implementation and validation

Each phase is divided into a number of work packages:

Phase 1:

WP1: Project management

WP2: Definition of scope and overall system analysis

WP3: Detailed analysis and selection of concept for prototype unit

WP4: Development and test of prototype unit

Phase 2:

WP5: Demonstration and implementation

WP6: Dissemination

The work packages are described in the following.

WP1: Project management

The activities include coordination of meetings, internal development seminars and end-user interaction, and further documentation of activities and financial reporting including final reporting.

WP2: Project boundaries and overall system analysis

Activities include definition of scope including framework conditions for end-user installations, health aspects, future DH networks and utilisation of return water from existing networks. Further, overall analyses are undertaken considering technical and financial aspects including comparison with alternative technologies and potential assessment. The objective is to identify a sound and competitive overall concept for the following detailed analyses.

WP3: Concepts and system analysis

Selection of concept and system design of prototype unit and units for demonstration is included in this work package.

WP4: Development of prototype

WP4 includes development, engineering and also laboratory tests of prototype unit.

WP5: Implementation and demonstration

The prototype unit is installed at a limited number of households for testing in a period of some months until project end in July 2013. Measurement parameters are set up, measurements are carried out and the performance is evaluated.

WP6: Dissemination

Activities include preparation of articles for trade journals and participation in seminars.

2 PROJECT SCOPE AND OVERALL SYSTEM ANALYSIS

2.1 Scope

The project focuses as a starting point on future LTDH in Denmark, but with an international perspective.

Buildings that could be relevant for LTDH supply are complying with Danish Building Regulations BR15 or better in relation to energy consumption.

For this project, the point of interest is an LTDH system with a supply temperature in the range of 35°-40° C. The return temperature for the system analyses is in the range of 20°-25° C.

Further, the heat pump must lift the temperature of the DHW to a level that matches the given concept. The concept includes a hot-water tank and this can in principle be installed on the primary side at a temperature level of 45°-50° C or on the secondary side at a temperature level of 55°-60° C.

The heat pump will not be used for space heating.

Sources for LTDH are numerous:

- New plants for distribution of hot water on 35°-45° C
- Return water from the existing DH system
- Waste heat from the industrial sector or similar
- Geothermal heat
- Solar heating
- Etc.

It is not within the scope of this project to undertake system analyses that include the heat sources for LTDH systems. However, in order to assess the potential it may become necessary to look at different heat sources related to LTDH as it may be prudent to differentiate the cost of the heat in relation to the temperature level.

Even though combining LTDH concepts with large heat pumps and district cooling or other cooling systems could be advantageous, analyses regarding this will not be included in the project.

In some situations, combining LTDH concepts with district cooling or other cooling systems can be advantageous. However and similar to the matter of the heat sources, analyses on this topic will not be addressed in this project.

The project focuses on individual single-family houses. Therefore, the thermal output from the heat pump unit is expected to be within the range of 500-1,000 W.

Experiences from earlier LTDH projects show that the LTDH network should be designed with relatively small pipe diameters (and thus high pressure loss) in order to minimize heat loss. When designing future LTDH networks the traditional DH network design, where the maximum supply temperature is set and peak demands are covered by increasing flow, should be modified so that the maximum supply temperature can be increased in order to cover peak demands.

Further, it should be considered to design future LTDH systems to meet a permanent summer heat demand for floor heating in bath rooms.

2.2 Heat demand analysis

When designing LTDH networks and especially the installation at the end-user, it is important to take the expected real heat demand and its annual variations into account.

For new buildings and houses fulfilling the requirements in the existing building regulations (BR10) and also the increased requirements of low energy buildings class 2015 and class 2020, the maximum allowed specific energy consumption for space heating, ventilation, cooling and domestic hot water is reduced.

In order to investigate the effect on the LTDH network and the end-user installation heat demand, analyses have been carried out for two types of single-family houses that fulfil the requirements for low energy buildings class 2015.

The energy demand is calculated/simulated for two types of single-family houses built in accordance with class 2015. The first house type is a semi-detached house with a gross area of 95 m², the second house type is a stand-alone single family house with a gross area of 159 m². Both houses are designed to be supplied by the district heating (DH) system.

The energy demand of newly built buildings should fulfil the requirements defined by the Building Regulations (BR), recently BR10. BR10 specifies three different classes of energy demand. The reference level is class BR10 and the energy demand is reduced for buildings in class 2015 and even more for class 2020. The energy demand for residential buildings includes energy for space heating and DHW heating and energy needed for operation of the ventilation system and pumps for building services. The energy framework for residential buildings in accordance with class 2015 is defined by the equation

$$30 + 1000 / \text{heated area (gross) kWh/m}^2/\text{y.}$$

The left column of Table 1 presents an overview of the input parameters used for calculation of the energy demand in accordance with BR10.

Table 1 – Comparison of input values required by BR10 and expected real values

	Values in accordance with BR10 & Anv213	Expected real values
DHW demand	250L/(m2.a) of 55°C warm DHW (2) (3)	800kWh of DHW (45-10) per person (4)
Internal heat gains	5W/m2 (heat gains on inner area)	5W/m2 or 3W/m2
Set point temperature for space heating	$t_{air}=20^{\circ}\text{C}$	$t_{operative}=22^{\circ}\text{C}$ (24°C in bathroom)

The calculations are carried out in three different cases (A, B and C) depending on temperature set-points and assumptions. See the table below.

Table 2 – Definition of simulated cases

Case	Set-point temperature [°C]		Heat gains [W/m2]	DHW
A	Air temperature	20	5	250 of 55°C L/(m2.a)
B	Operative temperature	22/24	5	800kWh/person.a
C	Operative temperature	22/24	3	800kWh/person.a

- Case A – in accordance with BR10 and Anv213 requirements
- Case B – due to expected user behaviour (space heating set-point temperature 22°C (bathroom 24°C) and higher DHW demand)
- Case C – same as case B, but internal heat gains are reduced from 5W/m2 to 3W/m²

The table below shows the results and an overview of the energy demand and design maximum heating power needed for space heating and DHW for the two simulated houses. The peak power results are valid only for floor heating with a defined composition of the floor and control.

Table 3 – Overview of results without and with application of primary energy factor

		95m ² - 3 persons				159m ² - 4 persons			
		Case A RAD	Case A	Case B	Case C	Case A RAD	Case A	Case B	Case C
Excluding primary energy factor	Energy demand for SH and DHW [kWh/a]	3706	3808	6024	6977	4564	4647	7210	8919
	Energy demand vs. case A [%]	97	100	158	183	98	100	155	192
	DHW [kWh/a]	1238	1238	2400	2400	2077	2077	3200	3200
	SH + AHU [kWh/a]	2468	2570	3624	4577	2487	2570	4010	5719
	Peak power for systems [kW]								
	DHW [kW]	32.3*				32.3*			
	SH - floor heating + air heater [kW]	2.7	3.0	3.0	3.0	3.1	3.0	3.0	3.0

For further details, reference is made to Appendix 1 Heat Demand Analysis.

2.3 Network considerations

This section highlights the advantages/disadvantages from a technical, economic and energy related perspective for low temperature district heating (LTDH) with integrated heat pumps for preparation of domestic hot water (DHW) compared with traditional district heating.

The low temperature and traditional district heating systems are compared in a system supplying new low energy houses following the energy performance framework of the Danish building regulations BR10 class 2015. The comparisons between the systems are based on simulations of a new build area.

The new build area consists of an example with 116 family houses. Two cases are considered. The first case is terrace houses with an average area of 95 m². The second case is detached houses with an area of 159 m². For simplification, detailed network simulations are made for the detached houses and the consequences for the terrace houses are discussed based on the results and conclusions for the detached houses.

All of the newly built houses have floor heating. The temperature needed for space heating is therefore only 30-35 °C. For domestic hot water the temperature requirement at the tap is 45 °C.

In traditional systems and future low temperature systems, without any temperature booster for DHW, the supply temperature should be at least 65 °C, when the DHW tank is placed on the secondary side. This is not a limitation for a low temperature system with an integrated heat pump.

The technical solutions are therefore different depending on whether a traditional system or a low temperature system with a heat pump is used. By simulating different network solutions the most economical and technically best solution is found.

The dimensioning of the network and heating equipment is based on the realistic consumption in accordance with the table below.

Table 4 – Heat and peak capacity demand for the simulated houses

Houses types	Energy Frame	Heat demand per year			Capacity
		space heating kWh	DHW kWh	Heat demand kWh	peak demand kW
95 m ²	Class 2015 frame	---	---	3850	---
	Class 2015 calculated	2600	1241	3841	---
	Realistic consumption	3700	2400	6100	3,4
159 m ²	Class 2015 frame	---	---	5770	---
	Class 2015 calculated	2524	2077	4601	---
	Realistic consumption	4040	3200	7240	3,4

The network analysis and considerations are carried out for variants with the hot water storage tank on the primary and the secondary side, respectively. Further, the analysis is done with various supply temperatures (65°C - 35°C).

For systems with DHW tank on the secondary side, there is a requirement of 65°C in the network at the critical consumer to prevent legionella formation. There are no problems with legionella when hot water is stored on the primary side. To provide domestic hot water at 45-50 °C, a temperature of 50-55 °C is needed in the storage tank.

Heat losses turn out to be 40-55% lower in newly designed low temperature district heating networks compared to traditional networks.

To keep investment costs down, it is recommended to design the new low temperature district heating networks for a temperature difference between supply and return of at least 40°C during peak hours. The supply temperature should therefore be raised during peak hours.

The results of the case study in terms of heat losses and pump energy are presented in the table below.

Table 5 – Heat losses and operation costs for different district heating networks

Scenarios		Heat loss in network			Pump energy		Operation cost	savings
		MWh	%	kr.	MWh	kr.	kr.	%
Traditional network	DHW, secondary side	164,4	16,4	57.531	1,05	1.055	58.586	-
	DHW, primary side	143,0	14,6	50.056	1,58	1.581	51.637	(12)
LTDH network	DHW, primary, 45 C	104,0	11,0	36.404	3,36	3.355	39.759	(32)
	DHW, primary, 65 C	98,2	10,5	34.362	3,65	3.651	38.013	(35)
	DHW, secondary 45 C	66,6	7,3	23.298	10,08	10.078	33.376	(43)
	DHW, secondary 65 C	70,7	7,8	24.732	6,66	6.663	31.396	(46)

The reduced operational costs for low temperature district heating networks compared to traditional networks are, however, not sufficient to cope with the increased investment costs for consumer units. The other benefits of LTDH such as improved efficiency of CHP supply plants, easier integration of RE technologies (ex. solar and geothermal energy) and industrial surplus heat have to be taken into account.

For further details, reference is made to Appendix 2 Traditional Network versus LTDH Network with Heat Pumps.

2.4 Concept and system analyses

Basically, there are two system concepts for consumer installations depending on the location of the hot-water tank; it can be placed either on the primary side or on the secondary side of the DH system.

2.4.1 Hot-water tank on the primary side

By placing the hot-water tank on the primary side, the water can be stored at 50° C and the DHW can be supplied through an instant plate heat exchanger.

A number of conceptual variants for integration of the heat pump are possible. The hot-water tank can primarily be supplied by the DH supply water, the heat pump can increase the temperature of a minor sub-flow, and by mixing this, the required e.g. 50° C in the hot-water tank can be obtained. The concept is illustrated in the figure below.

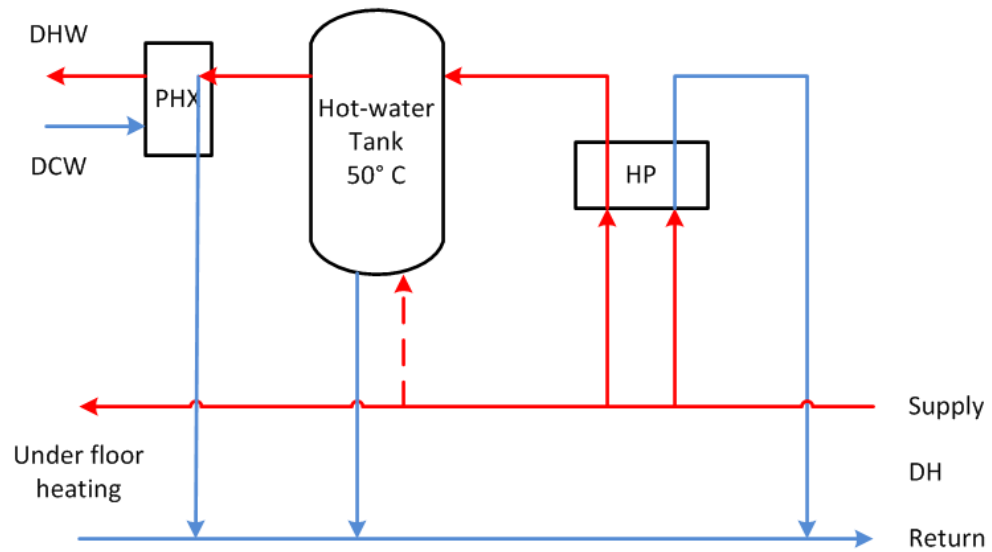

Figure 1: Concept with hot-water tank placed on the primary side. DHW: Domestic hot water, DCW: Domestic cold water, PHX: Plate heat exchanger, HP: Heat pump.

2.4.2 Hot-water tank on the secondary side

By placing the hot-water tank on the secondary side, the heat pump must increase the DHW temperature to e.g. 60° C because of the risk of legionella contamination.

Different concept variants are possible. For example heat can be transferred from the DH supply before it enters the heat pump. This concept is illustrated in the figure below.

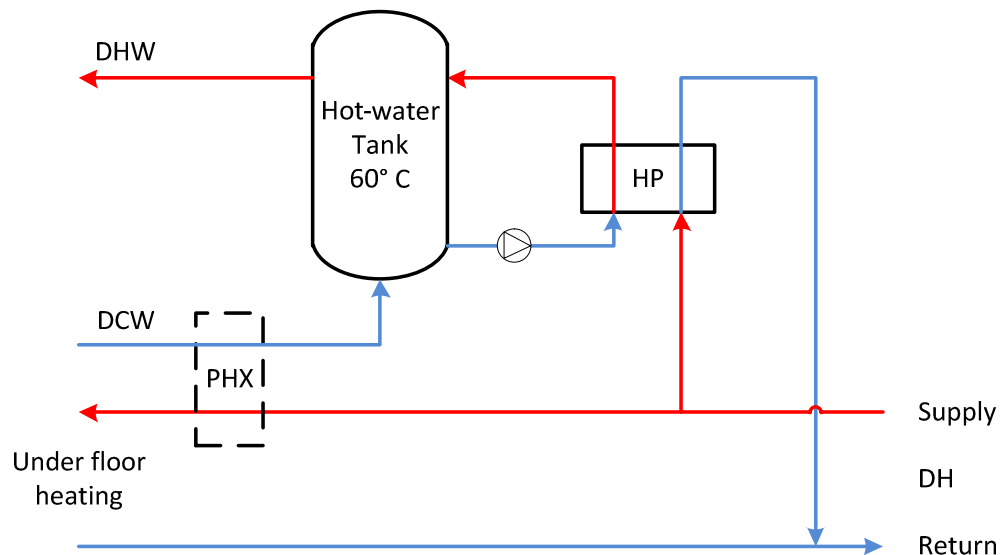

Figure 2: Concept with hot-water tank placed on the secondary side. DHW: Domestic hot water, DCW: Domestic cold water, PHX: Plate heat exchanger, HP: Heat pump.

2.5 Comparison with other technologies

The basic concept of hot water supply in low temperature district heating has been compared to conventional district heating systems in terms of overall energy and exergetic efficiency.

The exergy utilization in the systems presented does not include the CHP production, so the primary energy utilization is only about half of the values presented.

The two variants of hot water storage location (primary and secondary sides) have been analysed separately.

It turns out that the exergetic efficiency of the conventional system configuration is higher than in the low temperature cases. This is caused by the low exergy content of heat at the relatively low temperatures in the system. However, the difference in efficiency is low if compared to the best low temperature solutions which are R134a heat pump with primary side tank and with secondary side tank and preheating. The former is considered the best solution and it will obtain exergetic efficiency of the same values as the conventional system if the minimum temperature differences in the heat pump evaporator and condenser are lowered to 2.5 °C.

The results show that a solution with R134a, or other subcritical systems, with heat storage on the primary side, will have the lowest primary energy consumption. A Transcritical R744 solution or an R134a solution with preheating - both with heat storage on the primary side - may also be considered as they have similar performance.

For further details reference is made to Appendix 3 Basic Concepts of Hot Water Supply in Low Temperature District Heating Networks.

2.6 Further concept analyses and design

The different concepts and variants for adaption of hot-water tank and heat pump have been analysed in more detail with the objective of identifying the optimal design, considering:

- Maturity of the technology
- Investment
- O&M costs

Other key parameters for the heat pump design are use of a natural refrigerant, high COP and small size.

Reference is made to section 3 below.

2.7 Potential assessment

2.7.1 Introduction

This section assesses the potential and applicability of the new concept on LTDH.

The assessment and considerations are made in three different segments of the district heating market:

- New-built areas where district heating is considered;
- Decentralised district heating systems which are very common in Denmark;
- Major district heating systems in connection with transmission systems and central power plants.

The division of the district heating market is necessary especially because of the influence and interaction of the LTDH concept with the upstream conditions and operations of the district heating system.

Further, it is necessary to distinguish between new-built areas either as a stand-alone system or as an area which is considered connected to an existing system.

Finally, the potential for connecting nearby consumers on e.g. oil or natural gas is addressed.

2.7.2 Assessment of potential in Denmark

Structure of the Danish district heating

The net energy demand for space heating is approx. 57 TWh/y (2010)¹. In 2030 this figure is expected to decrease to perhaps 45 TWh/y due to energy efficiency measures.

In 2010 approx. 50 % of the total energy demand for space heating was covered by district heating.² The potential share of district heating is 70 % if houses and buildings with oil and gas based individual heating near existing district heating schemes are connected¹.

Based on the above, the potential extension of district heating is calculated to be around 2 TWh until 2030¹.

By 2030 it is expected that new buildings will contribute with approx. 4 TWh/y¹.

The share of district heating sources, where the heat is produced, is

- central power plants: 47 %
- decentralised heat and power plants: 30 %
- heating plants: 23 %

Green field projects

Future stand-alone green field district heating systems will be established with lower supply temperatures compared to the traditional 80/40 °C. In the future, the traditional

¹ Varmeplan Danmark 2010.

² Varmeplan Danmark and Energistatistik 2010.

system is not expected to be competitive in relation to neither individual solutions nor low temperature district heating.

The low temperature option of a say 65/30 °C system allows preparation of hot tap water without the necessity of a booster heat pump.

The low temperature considered in this project with a temperature set of approx. 40/20 °C needs the booster heat pump for hot water preparation.

Whether the future systems will be based on one or the other low temperature concept is difficult to predict. It will depend on investment and operation costs during the lifetime of the system. An evaluation would require detailed knowledge of CHP operation and heat losses in DH network, which is not within the scope of this analysis.

From an exergetic and energy efficiency point of view, the low temperature district heating option is very applicable especially under combined heat and power production. See also Appendix 3.

In 2030, it is expected that new buildings will demand some 4 TWh/y. The development until 2030 can reasonably be considered as linear.

Decentralised district heating systems

The decentralised district heating systems in Denmark cover slightly more than 30 % of the existing district heating market.

The existing schemes typically operate at the traditional temperature set 80/40 °C, however with a lowered supply temperature during summer time.

Most of the schemes are Combined Heat and Power facilities (CHP), where lowering of the return temperature can be highly appreciated.

Connecting a new green-field area or extending the existing scheme by new consumers supplied from the return line is a good example of increasing the electrical efficiency at CHP plants and capacity of an existing network scheme.

The LTDH concept further creates excellent conditions for water vapour condensation in the flue gas if this is not already utilised.

District heating systems in connection with central power plants and transmission systems

In Denmark, examples of major district heating systems and/or transmission systems connected to central power plants are: CTR (Copenhagen area), VEKS (Western Copenhagen area), TVIS (East Jutland), Aarhus, Aalborg and Odense.

In general, the heat supply companies are connected to either the transmission system or the central power plant by heat exchanger stations. From here they distribute to the consumers.

Because of the structure and size of these systems, an extended supply from the return line in the distribution system will have only minor effect on the efficiency and operation of the central plants and the transmission systems. An exergetic analysis actually turns out negative with respect to extending the existing network with the LTDH supply.

Extending the supply from the existing return line will, however, increase the capacity of the existing system, which in many cases could be of interest.

For the reasons stated above, the potential for the LTDH-unit is limited in connection with the major central district heating systems.

Technical potential in Denmark

With the existing structure, the expected development and the applicability of the LTDH concept, it is reasonable to conclude that the potential for the new unit is 50 % of the future district heating extensions and new buildings.

A forecast of a 2 TWh extension by 2030 related to the conversion of existing houses and buildings is equivalent to some 135,000 individual houses.

A forecast of a 4 TWh extension by 2030 related to new builds is equivalent to around 400,000 individual houses.

A 50 % market potential of the above is equivalent to 267,500 individual houses.

The main competitor to the expansion of the district heating network in Denmark is individual heat pump solutions, especially the ground source water/water based heat pump. This type, however, also requires a certain amount of space which in many cases is a problem.

2.7.3 Assessment of potential outside Denmark

The potential for LTDH abroad is quite difficult to estimate. In reality, it will be limited to newly built systems where the modern district heating technology can be applied.

Especially EU countries focus on combined heat and power production and on energy efficiency in general. Green field district heating schemes seem most suitable, independently of whether they are based on renewable energy sources or not.

However, the potential is worldwide in the long term.

3 DETAILED SYSTEM ANALYSIS

3.1 Detailed concept description

This purpose of this section is to evaluate the most promising candidates in terms of energy efficiency for the tap water heat exchanger, heat pump and storage system with variable forward and return temperatures in the district heating system. Not all of the different candidates are evaluated, as some could be disregarded due to practical constraints. The evaluation considers both the first and second law of thermodynamics, as the systems will be part of a major calculation of efficiency.

Two basic concepts are considered: primary side (district heating water heated in a condenser and stored in the tank) and secondary side (tap-water heated in a condenser and stored in the tank - requires a set minimum temperature to avoid legionella). Additionally, the most promising concept is changed, in order to evaluate the effect of using district heating return to supply the source heat for the evaporator.

The analysed concepts are:

- A1 - Variant primary
- A2 - Variant primary (with/without preheating)
- B1 - Variant secondary (with/without preheating)
- B2 - Variant secondary
- C1 - Variant primary (source heat from district heat return line)

The assumptions for the integration analysis of the heat pump are presented in the table below.

Table 6 – Assumptions for low temperature district heating network heat pump

Variable	Assumption
Pinch temperature in Tap-water HEX (Q=32 kW)	8 [K]
District heating Network forward	40 [C]
District heating Network Return	22 [C]
Refrigerant	R134a
Isentropic efficiency of compressor	0,5 [/]
Pinch in condenser and Evaporator	2,5 [K]
Tap water out (at both types of load)	45 [C]
Tap water in	10 [C]
Minimum temperature in secondary tank	58 [C]

Three different variants were selected for detailed analysis. These were:

A1 – Lowest power consumption of the investigated configurations independent of the district heating forward and return temperatures.

B2 – Most efficient “secondary” solution. Lower second law efficiency due to the increased temperature level of the storage tank, and mixture after storage tank. Close to the performance of A1.

C1 – Possibility to reduce return temperatures significantly (2-5 K depending on configuration). With space heating, this variant has the highest second law efficiencies.

The configuration A1 is presented in the figure below.

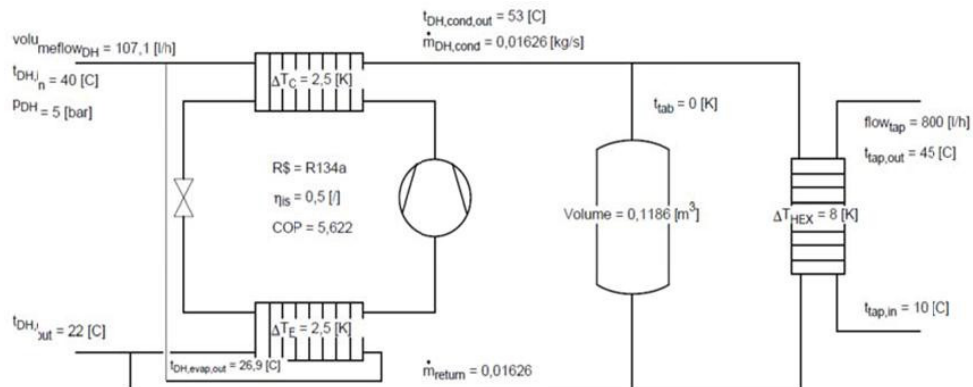

Variant	DH	DH (max)	Condense	P	Heat pump	Water Volume	Exergetic eff.
	[l/h]	[kW]	[kW]	[kW]	COP	[L]	[/]
A1	107,1	2,22	0,88	0,157	5,62	118,6	0,44

Figure 3: Simplified diagram of variant A1.

For further details reference is made to Appendix 4 Calculations on Different Concepts for LTDH HP.

3.2 Dimensioning of hot-water tank

The hot-water tank is a key component of the system concept and proper dimensioning of the tank is crucial for the end-user experience. The tank shall be able to deliver the peak demand based on the consumption profile and not be oversized as this causes inappropriate heat losses.

The hot water consumption and tapping profile do not depend on different concepts of micro-booster heat pump system, where either 55°C district heating water or 60°C domestic hot water is stored. According to the Danish water standard DS 439 hot water consumption includes the tapping sequence shown in the table below repeated every 12 hours.

Table 7 Domestic hot water consumption profile according to DS 439

	Q	$Duration$	$Repeated$ $within\ 12$ $hours$	$Temperature,$ T_{hot}	$Capacity$ $requirement^*$	$Energy$ $consumption$
	l/s	s		$^{\circ}C$	kW	kWh
Shower	0.14	300	4	40	17.6	1.47
Kitchen tap	0.10	150	2	45	14.7	0.61
Hand wash	0.056	180	4	40	7.0	0.35

* Cold water temperature is $T_{cold}=10^{\circ}C$

The hot-water tank volume depends on the position of the tank (primary or secondary side) as the temperature levels are different.

The calculated size of the storage tank (V_{eff}, l) is presented in the tables below. The tables also include peak flow rates from the storage tank only and the total peak flow rate, when the contribution from the heat pump is included.

Table 8 – Sizing of hot water/district heating water storage tank

	T_w	T_{cold}	$E_{required}$	E_{hp}	E_{eff}	V_{eff}	$Peak\ flow$ $rate\ from$ $storage$ $tank$	$Total\ peak$ $flow\ rate$ $(tank+heat$ $pump)$
	$^{\circ}C$	$^{\circ}C$	kWh	kWh	kWh	l	l/h	l/h
Primary side	55	17	7.1	2.4	4.7	106	679	729
Secondary side	60	10	7.1	3.16	3.94	68	504	554

Table 9 – Comparison of calculated storage tank size with 50 l/h charging flow rate

	$\Delta T_{LTDH} / \Delta T_{prim(sec)}$	V_{LTDH}, l	$V_{prim(sec)}, l$	V_{eff}, l
Primary	0.89	152	$152 \cdot 0.89 = 135.3$	106
Secondary	0.68	152	$152 \cdot 0.68 = 103$	68

It is clear that the volume of domestic hot water or district heating water also depends on the flow rate from micro-booster heat pump, which supplements the flow from the tank during hot water tapping. The higher the flow from micro-booster, the smaller the storage tank that can be used, see the figure below.

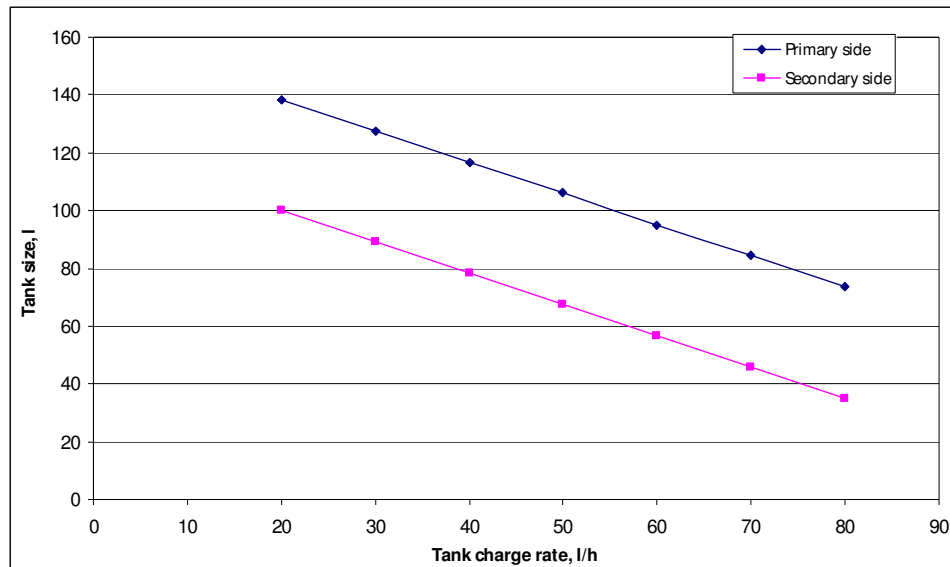

Figure 4: Hot water and DH water storage dependency on the complementary flow from the micro-booster heat pump during hot water tapping.

For further details, reference is made to Appendix 5 Domestic Hot water and District Heating water Storage Tanks.

3.3 Selection of concept for prototype

The concept chosen for prototype fabrication and demonstration is the variant A1, see the previous Sections 3.1 and 3.2.

The hot water storage tank should be selected with an effective volume of at least 106 litres based on a temperature difference of 38 °C between storage temperature and the cold water return temperature on the primary side and a charge flow rate of 50 litres/hour.

4 DEVELOPMENT OF PROTOTYPE UNIT

4.1 Design parameters

The main characteristics of the heat pump unit are listed in this section.
Operational parameters:

DH supply temperature max.: 100 °C
 DH supply temperature min. 30 °C
 DH differential pressure: 30 kPa to 400 kPa
 Max. pressure on the DH side: PN10
 Max. CW pressure: PN10

Design DH supply temperature: 40 °C
 Design charging temperature to tank: 55 °C
 Design DH return temperature (DHW only): 30 °C
 Design DHW temperature: 45-50 °C
 Design DHW capacity: 33 kW (DS439, version 4.)
 Design DH charging flow for DHW storage tank filling: 60 litres/h

Electric consumption max.: 250 W (230V, 1 Amp)
 COP of heat pump: 4.2 to 5.0, at design 4.5
 Refrigerant: R600a
 Safe mode: Bypass of heat pump possible by manual valves
 Tank volume: 135 litres (DH water)
 Typical heat loss: approx. 200W (assumed based on earlier experience)

A main characteristic for the design is that the tank is located on the primary side, i.e. there is district heating water in the storage tank. Further, the DH supply flow is split towards the heat pump - one part through the evaporator and a second part through the condenser.

The unit can operate without engaging the heat pump, in case the DH supply conditions are sufficient. This means a DH supply temperature above 55 °C and differential pressure above 50 kPa. This option is only for backup purposes in case the heat pump function fails.

The heat pump unit is built as a modular concept, fitting to standard dimensions of 60 cm x 60 cm. The height is 190 cm. The heat pump is mounted on a rail system in the lower part of the unit. In this way, easy servicing of the heat pump module is possible. The weight of the unit is 95 kg. Because of the design details of the cabinet, it is sufficiently robust.

Furthermore, the design is optimised for reduced space requirements, but still enables good servicing. The connection to the building is similar to a normal district heating unit, and in that regard no additional equipment are required.



Figure 5: Left: Cabinet, tank placed in the top part and heat pump, controls, heat exchanger, electronic controller and pipes in the lower part. Right: Lower part of heat pump unit.

At the top part, the tank is insulated. At the bottom part the critical components are insulated. This includes relevant pipes, heat exchangers and manifolds. Not all components can be insulated due to excess temperatures; examples are pumps, electronic controllers and the heat pump itself.



Figure 6: Laboratory test and unit assembly. All units were finally tested before shipment.

4.2 Detailed description of functionality

The final principle and the main components used for the heat pump unit are shown in the figure below:

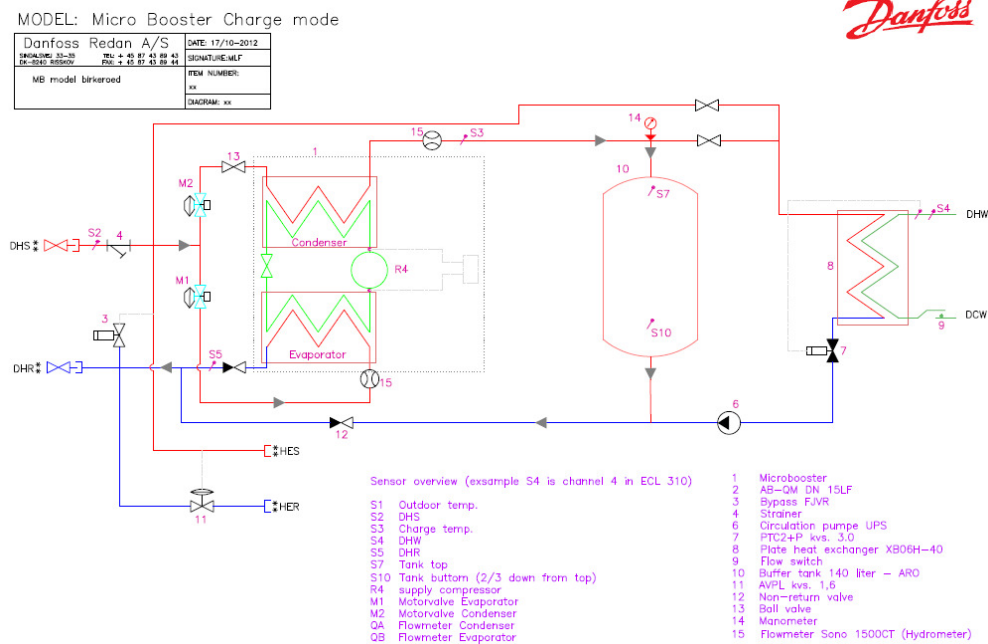

Figure 7: Final principle for realised prototype and units applied in the field test

TS7 and TS10 are measurements of the storage tank temperature. In case the temperature level is too low (below 53 °C), the charging function is engaged. The DH supply (DHS) flow is activated and split via M1 and M2. The first part is heated to the appropriate storage tank temperature through the condenser. The objective is to achieve a 55 °C charging temperature in the most efficient way (highest COP for the heat pump). The second part is cooled down through the evaporator.

Pressure balanced valves, M1 and M2, ensure optimal flows depending on the actual DHS temperature. In this way a wide range of DHS temperatures can be accepted. In case the DHS temperature is above 55 °C, the storage tank is still charged through the evaporator, but the heat pump remains off. The storage tank is filled from the top and the cold lower volume of the storage tank is led directly back to the district heating return DHR.

Flow meters 15 provide input to the controller regarding operational conditions, leading to a maximum COP under different DH supply conditions.

In case of DHW tapping, flow switch 9 and circulation pump 6 are activated. Stored DH water is led from the tank to the heat exchanger, producing DHW instantly. The return flow from the heat exchanger is led back to the lower part of the storage tank. In case the DHW tapping is occurring during charging, the flow is led directly from the evaporator to the heat exchanger. Still the majority of the flow to the heat exchanger comes from the storage tank. DHW controller 7 maintains a constant temperature, based on the signal from temperature sensor S7.

The heating system is conventional, with a direct connection and equipped with a dP controller. The basic version of the heat pump unit is for floor heating, where the

lower DHS temperatures can be accepted. Variations regarding the heating system can easily be implemented.

4.3 Test results

The tests were divided into 3 main phases. The first phase relates to the heat pump itself, with focus on COP. The second phase relates to the heat pump unit, especially the system function. The third phase relates to the field test and is addressed in section 5.

First test phase:



Figure 8: Heat pump prototype used for laboratory test

Initially, the amount of refrigerants was determined empirically. The operation conditions were similar to the design conditions and the optimization was made with respect to the COP. Typically, COP's in the range of 4.2 to 5.0 were measured.

The next step was to operate the heat pump at different DH supply temperature levels. This led to the determination of the optimal flows through the condenser and the evaporator depending on the DH supply temperature. This information is used by the controller, resulting in an optimum COP during operation. The supply temperature range was tested from 30 °C to 55 °C. The corresponding optimal flow through the condenser and evaporator was in the range of 25 to 150 litres/hr.

Second test phase:

The different operation modes were tested. This includes charging with and without an engaged heat pump, various DHW tapping profiles, operational temperature control for the components (overheat protection), test of controller code and DHW stability and DHW capacity check.



Figure 9: Left: Display of electronic controller, accessed via web portal (ECL portal). Right: System test equipment

Figure 9 left shows the display of the electronic controller during charging of the storage tank. The DH supply temperature is 39.2°C, the DH return temperature is 29.0°C, and the charging flow is 68 litres/hour. The outlet temperature from the evaporator is 55.8°C. The two heat exchangers on the display represent the evaporator and the condenser. The picture to the right shows a part of the test components.

It is beneficial to operate the system with a charging temperature of 50°C and a DHW temperature of 45°C. This way, the system efficiency can be improved, with regard to heat pump COP and DH return temperature.

Different charging and tapping sequences were tested. It was concluded that the 135 litre storage tank is sufficient with the applied charging flows and temperatures.

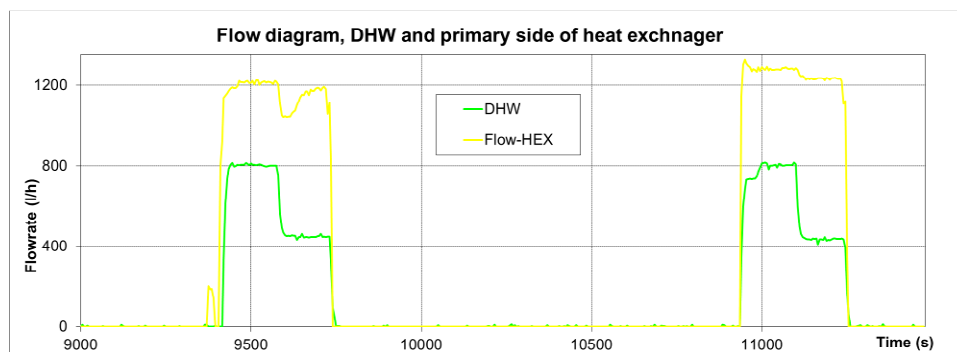

Figure 10: Charging and tapping sequences

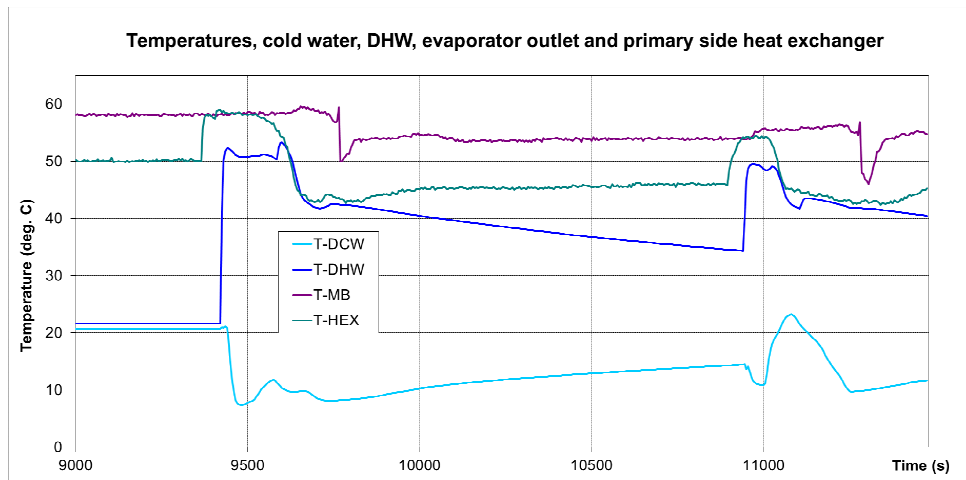

Figure 11: Example of dynamic DHW tapings, flow curves. Bottom: corresponding temperature curves. Tappings are made with a marginally charged storage tank.

From figure 11 it can be seen that the charging temperature is a bit higher than specified. Two tapings are seen in the upper figure. In both cases the storage tank is only marginally charged. The results are drops in DHW temperature during tapping. A number of those tests were performed to determine the optimal settings of the controller.

5 DEMONSTRATION AND IMPLEMENTATION

5.1 Demonstration site

The test units were initially planned to be installed in a demonstration site at Bytoften, Gladsaxe, north of Copenhagen. Bytoften is a planned new build area consisting of 116 family houses. The houses were planned to be built according to the Danish energy framework building regulations BR10 class 2015. Bytoften was perfect for a demonstration site because the high insulation level and floor heating would not require a supply temperature above 45 °C for space heating. The houses were also planned to be built without a circulation system for domestic hot water.

Because of huge delays in the constructions work due to the financial crisis in 2008, it was not possible to establish the demonstration site within time schedule of this project, and it was there decided to select another test site.

The new demonstration site includes 4 single houses in Birkerød, also north of Copenhagen. The 4 houses were constructed before 1960 and they all have circulation systems for domestic hot tap water.

Manenvej 20, 14B and 19 are all traditional 2-string systems with old radiators. Manenvej 14A has a 1-string system and is less suitable for low temperature district heating. 14A has many and large radiators which compensate for the 1-string system. Manenvej 20 and 19 have floor heating in one bath room.

A summary table of the 4 demonstration houses is presented below.

Table 10: Demonstration houses in Birkerød

Adresse		Internal area	House constructed	Oil/gas consumption	Heating Source	Estimated demand	Estimated power
Street	Number	m2	Year	m3/L		MWh	kW
Manenvej	20	110	1960	2542	oil	19	10
Manenvej	14A	146	1937/86	1500	n-gas	17	9
Manenvej	14B	154	1937/86	1200	n-gas	13	7
Manenvej	19	129	1953	3356	oil	25	14
Total		539				74	40

5.2 Implementation

5.2.1 District heating distribution network

The distribution network consists of a 205 m distribution network with a pipe diameter of 48.3 mm and 138 m branch pipes with a pipe diameter of 22 mm.

The 4 houses are supplied with heat from a shared heat exchanger placed in the basement of Andedammen 18. The temperature is lowered to 40-45 °C in the shared heat exchanger.

The total annual heat loss in the pipe system is calculated to be 31.5 MWh for a traditional network with a 80/40 °C system. Compared to the total heat demand of the 4 houses the heat loss is 30 %.

The total annual heat loss in the pipe system is calculated to be 17 MWh for the low temperature district heating network with a 40/30 °C system. Compared to the total heat demand of the 4 houses the heat loss is then 19 %. The heat loss reduction is almost equivalent to the annual heat demand for one house.

The distribution system for the 4 houses is seen in the figure below.

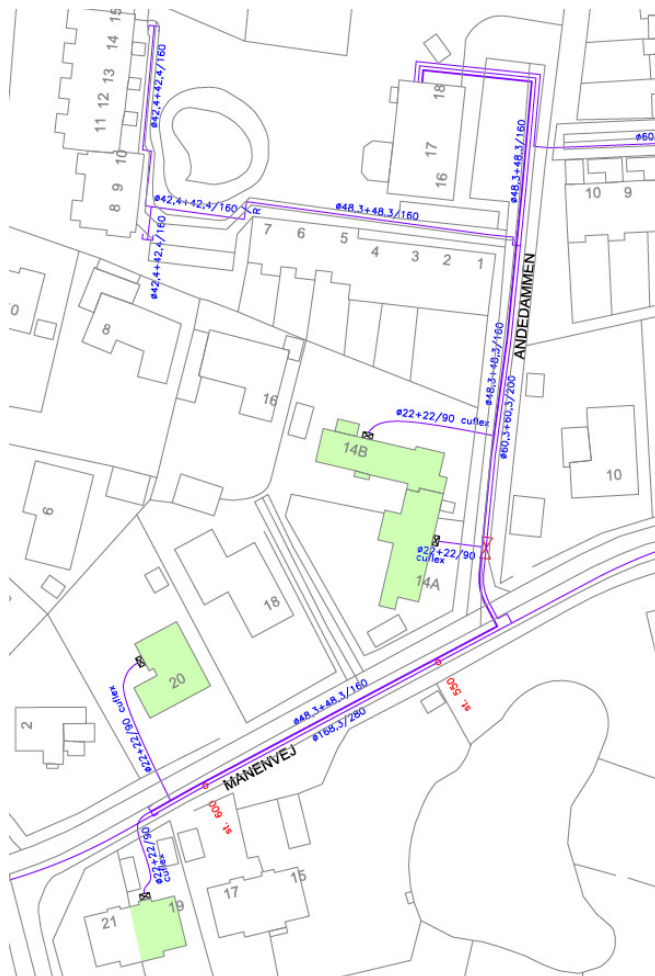

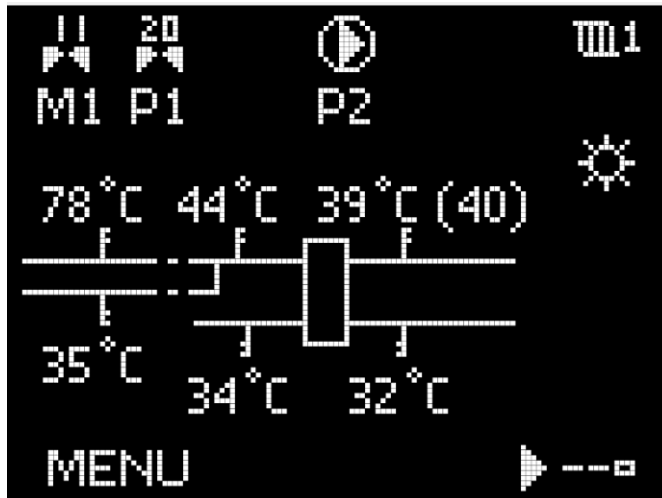

Figure 14: Web based supervision and control of the supply system

5.2.3 Micro Booster unit

The first micro booster unit was installed at Manenvej 19 on 4th February 2013 and the last was installed 28th February 2013. During the installation period and for a month afterwards, there were problems with air in the accumulator. The air was sucked from the top of the hot water storage tank through the heat exchanger to the hot tap domestic water and ended up in the circulation pump (6). The result was that it could not produce hot water.

During the installation period, each time a new house was connected more air was introduced into the system. An air removal system was established at the central supply heat exchanger, but it was difficult to remove all the air. After a couple of months automatic air removers were installed close to the pump and this solved almost all problems with air.

Manenvej 14 B has had most problems with air, and at a late stage in the project an automatic air remover was installed in the top of the storage tank. This solved the problem here.

Apart from problems with air, the micro booster unit has been very reliable and there has not been any problems with the heat pump itself.

A schematic diagram of the unit installation is shown in the figure below.

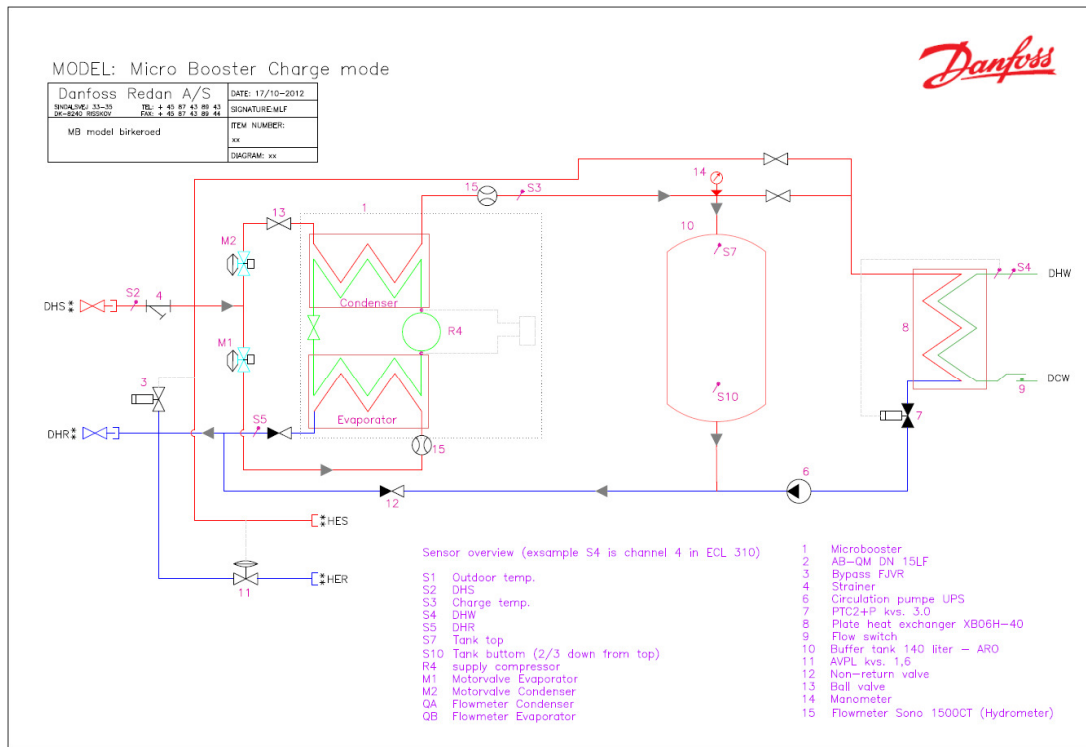

Figure 15: Diagram of the low temperature district heating unit.

Pictures of the units installed are shown below.





Figure 16: Pictures of one of the low temperature district heating units

A short user manual for the unit is found in Appendix 6 (in Danish).

5.2.4 Efficiency of DHW production

The efficiency of the DHW production is largely dependent on the supply temperature. The heat pump is less dependent, varying between 4.2 and 5 for supply temperatures between 35 and 50°C.

The overall efficiency of the DHW production is larger than for the heat pump, because a part for the heat transferred through the DHW heat exchanger is delivered from the supply temperature. At a 55 °C supply temperature there is no need for the heat pump and the compressor does not use any power.

With a supply temperature at 40 °C and an annual DHW demand at 3.200 kWh, the electricity consumption is 290 kWh (the heat loss in the hot water storage tank is not included).

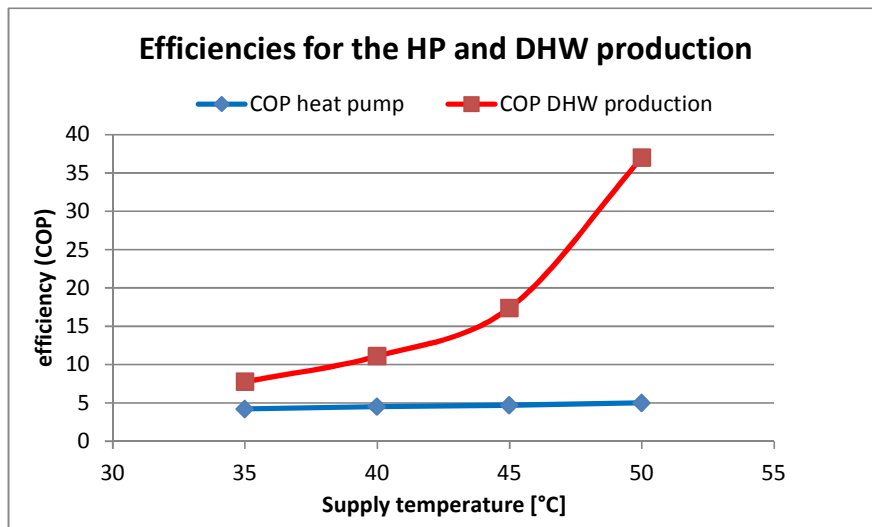

5.2.5 Domestic hot circulation water

All four consumers had already installed a hot water circulation system. However, the micro booster unit not designed for this. If hot circulation water is connected to the storage tank the stratification will be mixed and thereby the function of the unit will be destroyed.

Instead, an independent circulation heat exchanger was established as showed in the figure below. The low temperature network heats up the circulation water to an acceptable temperature. With an electrical switch the circulation pump shuts off when the consumer starts tapping hot water so that the circulation system does not alter the supply temperature.

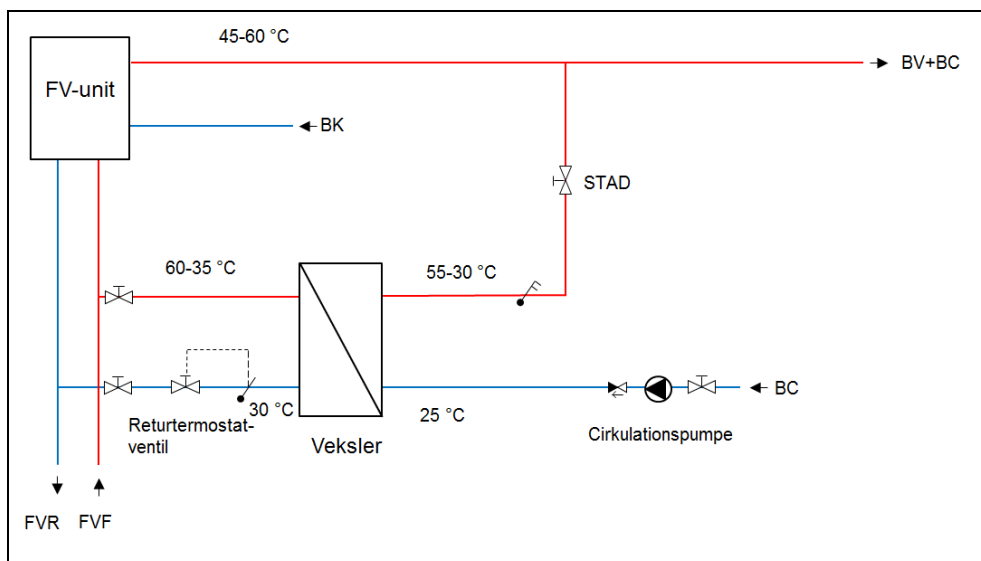

Figure 17: Special measure to separate the internal circulation system from the units was necessary

5.2.6 Tariff system

The tariff system at Nordforbrænding I/S network consists of three elements:

- A variable element depending on the heat consumption in MWh.
- A fixed element based on the customer's indoor floor area.
- A variable element depending on the flow consumption in m³/year.

The LTDH customer pays the same for the heat consumption and the indoor area as a normal DH customer, but has a cut off on the flow consumption. The customer only pays for the flow from the supply string that boosts the return temperature at the shared heat exchanger. This way, the customer has an incentive to lower the shared supply temperature.

When consumers only use the return water from the main and existing network, there is no impact on the main pumps at the central supply station at Nordforbrænding.

5.3 Test results

For all 4 installed heat pump units detailed data loggings were made. One example is included in the figure below:

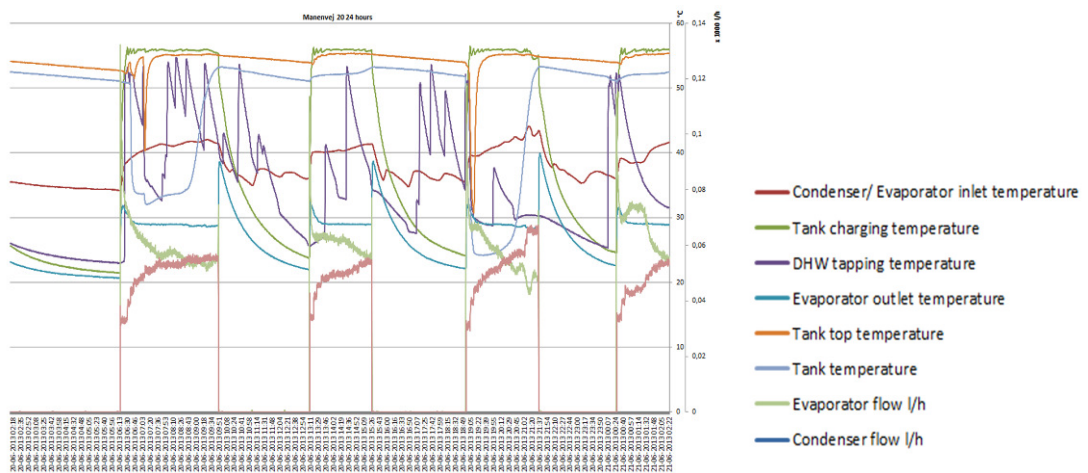

Figure 18: Temperature and flow data from field test. Duration 24 hours

Figure 18 shows 4 charging periods during a 24 hour period. The charging temperature is 55°C, DHW tapping temperature approx. 52°C, DH supply temperature approx. 40°C and DH return temperature approx. 29°C (evaporator outlet temperature). Flows were in the range from 30 to 60 litres/hour. The figure basically shows that the heat pump unit operates as expected.

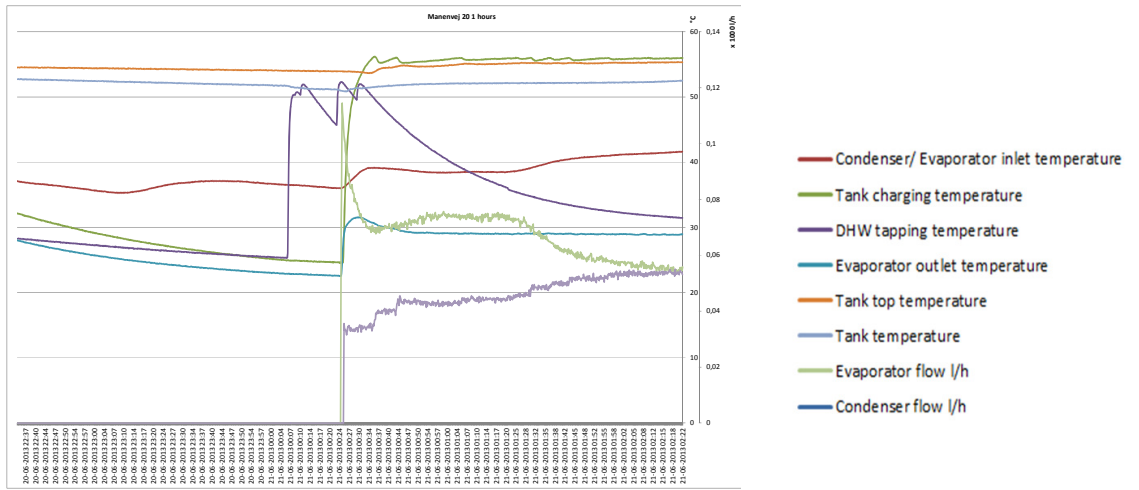

Figure 19: A one-hour window from the field tests

Below the supply temperature and the flow through the energy meter is shown for Manenvej 14A and Manenvej 20. The flow is very constant for Manenvej 14A and this is a result of the one string system. Around 1st June Manenvej 14A closed for the radiator system and the flow dropped to around 100L/h.

Manenvej 20 has a more fluctuating flow. By mid-June most of the radiator system was shut down except for the floor heating system.

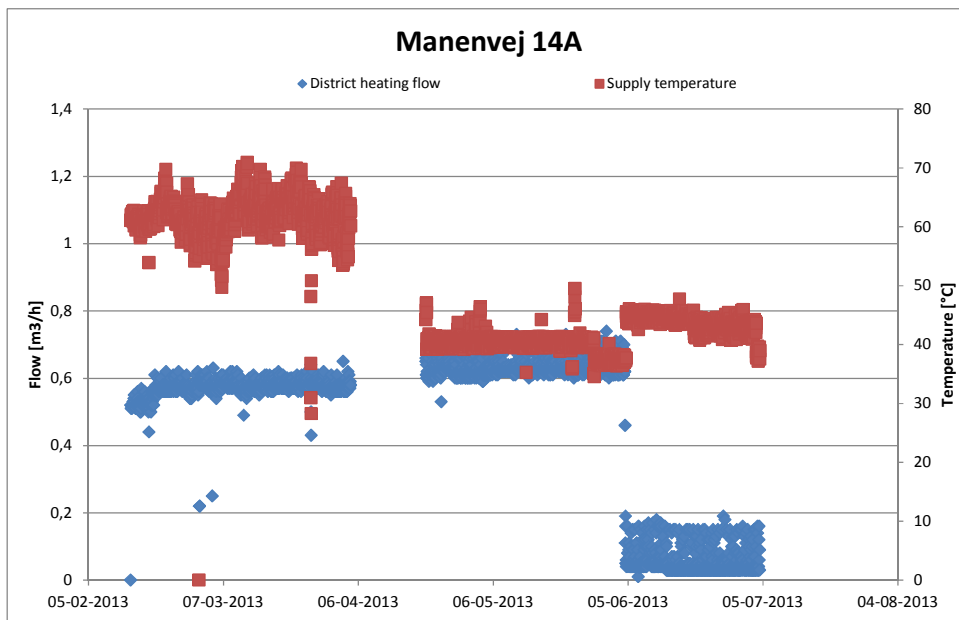

Figure 20: Field tests for the consumer on Manenvej 14A. Supply temperature and flow rate

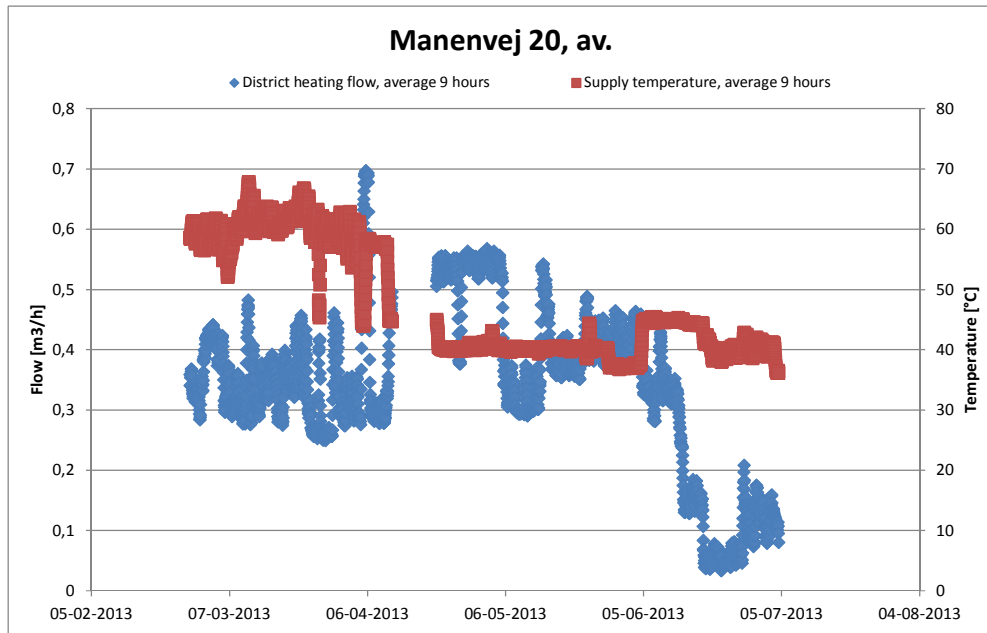

Figure 21: Field tests for the consumer on Manenvej 20. Supply temperature and flow rate

6 DISSEMINATION

The project was first presented at the annual conference Dansk Fjernvarmes Årsmøde in November 2011 by Grontmij.

An article on low temperature district heating and the project was presented in the district heating magazine Dansk Fjernvarme Nr. 3, March 2012: "Nyt EUDP-projekt løser problemerne med brugsvand ved lavtemperaturfjernvarme på 45 °C" [1].

In March 2012 the project was presented in a paper and a presentation was given by Danfoss at the international conference on District Energy (SDDE) in Slovenia 2012: Impact of lowering dT for heat exchangers used in District Heating Systems [2].

Further, the project was presented in a paper at the 25th International Conference on Efficiency, Cost, Optimization, Simulation and Environmental Impact of Energy Systems in June, 2012 Perugia Italy [3].

The following papers were presented at the 13th International Symposium on District Heating and Cooling in Copenhagen September 2012:

- Low Temperature District Heating Consumer Unit with Micro Heat Pump for Domestic Hot Water Preparation [4];
- Impact on Lowering dT for Heat Exchangers used in District Heating Systems [5];
- The Effects of Lowering the Network Temperatures in Existing Networks [6].

Finally, an article was presented in the journal Danish District Heating Board No. 3 2013: Great Potential and Interest in Low Temperature District Heating with a Supply Temperature of 35-45°C [7].

7 CONCLUSIONS AND NEXT STEPS

The main conclusions of the project are:

- The main driver for low temperature district heating is utilisation of low temperature energy sources (solar heat, geothermal energy, heat pumps etc.) combined with low energy losses in a distribution system with a decreasing energy specific demand;
- Direct connection with a hot water storage tank on the primary side and without an internal circulation system for hot tap water has proved to be the best concept;
- The potential of the micro-booster system is huge. It is applicable to both new design systems and for integration with existing district heating systems.
- The micro-booster itself has a COP of approx. 4.5 under the set project boundaries and conditions, however the overall system COP of the hot tap water preparation is many times higher;
- The implemented project in Birkerød Denmark shows good and robust operational performance;

The recommended next steps are:

- Demonstration phase 2 of the concept with approx. 10-15 houses of relatively modern design without internal circulation systems for hot tap water;
- Demonstration/verification of the annual share of the total heat demand that can be met by low temperature supply in the existing building stock;
- Demonstration and economic feasibility of the concept in connection with renewable energy sources.

8 REFERENCES

- 1) Fjernvarme Nr. 3, March 2012: Nyt EUDP-projekt løser problemerne med brugsvand ved lavtemperaturfjernvarme på 45 °C. Johnny Iversen, Grontmij.
- 2) International conference on District Energy (SDDE) in Slovenia 2012: Impact of lowering dT for heat exchangers used in District Heating Systems. Jan Eric Thorsen Danfoss and Johnny Iversen Grontmij.
- 3) The 25th International Conference on Efficiency, Cost, Optimization, Simulation and Environmental Impact of Energy Systems in June, 2012 Perugia Italy. Torben Ommen and Brian Elmegard DTU Mek.
- 4) The 13th International symposium on District Heating and Cooling in Copenhagen 2012: Low Temperature District Heating Consumer Unit with Micro Heat Pump for Domestic Hot Water Preparation. Jan Eric Thorsen Danfoss and Johnny Iversen Grontmij.
- 5) The 13th International symposium on District Heating and Cooling in Copenhagen 2012: Impact on Lowering dT for Heat Exchangers used in District Heating Systems. E. Zvingilaite and M. L. Franck Danfoss et al.
- 6) The 13th International symposium on District Heating and Cooling in Copenhagen 2012: The Effects of Lowering the Network Temperatures in Existing Networks. O. Gudmundsson Danfoss, A. Nielsen Grundfos and Johnny Iversen Grontmij.
- 7) Danish Board of District Heating No. 3 2013: Great Potential and Interest in Low Temperature District Heating with a Supply Temperature of 35-45°C. Johnny Iversen Grontmij.